

EDKRBM002
13367516

Global Drive



Mounting Instructions

ERB 20 ... 35 W

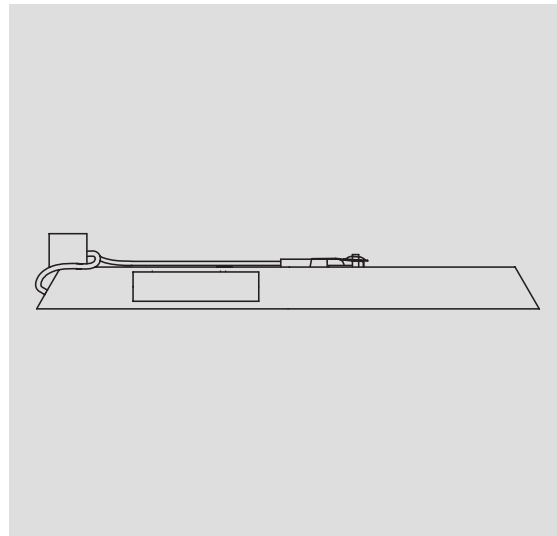

ERBM470R020W, ERBM100R035W

Brake resistor



Lesen Sie zuerst diese Anleitung und die Dokumentation zum Grundgerät, bevor Sie mit den Arbeiten beginnen!
Beachten Sie die enthaltenen Sicherheitshinweise.



Please read these instructions and the documentation of the standard device before you start working!
Observe the safety instructions given therein!



Lire le présent fascicule et la documentation relative à l'appareil de base avant toute manipulation de l'équipement !
Respecter les consignes de sécurité fournies.

1	About this documentation	24
	Validity information	24
	Target group	24
	Document history	24
	Conventions used	24
	Notes used	25
2	Safety instructions	26
	General safety instructions	26
	Residual hazards	27
3	Product description	29
	Overview	29
	Identification	29
	Application as directed	30
	Dimensioning conditions	31
4	Technical data	33
	General data and operating conditions	33
	Rated data	34
	Mechanical data	35
5	Mechanical installation	36
	Mounting steps	36
6	Electrical installation	37
	Important notes	37
	Connection data	37
	Connection plan	38
	Mounting steps	39
7	Maintenance	40
	Maintenance intervals	40
	Maintenance operations	40

1 About this documentation

Validity information

Validity information

These instructions are valid for

- ▶ Brake resistors ERBM470R020W
- ▶ Brake resistors ERBM100R035W

Target group

This documentation is directed at qualified skilled personnel according to IEC 60364.

Qualified skilled personnel are persons who have the required qualifications to carry out all activities involved in installing, mounting, commissioning, and operating the product.



Tip!

Information and auxiliary devices around the Lenze products can be found in the download area at <http://www.Lenze.com>

Document history

Material number	Version			Description
13367516	4.0	02/2011	TD29	Revision

Conventions used





Type of information	Identifica-tion	Examples/notes
Spelling of numbers		
Decimal separator	Point	In general, the decimal point is used. For instance: 1234.56
Warnings		
UL warnings		Are only given in English.
UR warnings		
Text		
Program name	» «	PC software For example: »Engineer«, »Global Drive Control« (GDC)
Icons		
Page reference		Reference to another page with additional information For instance: 16 = see page 16

Notes used



The following pictographs and signal words are used in this documentation to indicate dangers and important information:

Safety instructions



Structure of safety instructions:

	Danger! (characterises the type and severity of danger) Note (describes the danger and gives information about how to prevent dangerous situations)
Pictograph and signal word	Meaning
	Danger! Danger of personal injury through dangerous electrical voltage. Reference to an imminent danger that may result in death or serious personal injury if the corresponding measures are not taken.
	Danger! Danger of personal injury through a general source of danger. Reference to an imminent danger that may result in death or serious personal injury if the corresponding measures are not taken.
	Stop! Danger of property damage. Reference to a possible danger that may result in property damage if the corresponding measures are not taken.

Application notes

Pictograph and signal word	Meaning
	Note! Important note to ensure troublefree operation
	Tip! Useful tip for simple handling
	Reference to another documentation

Special safety instructions and application notes for UL and UR

Pictograph and signal word	Meaning
	Warnings! Safety or application note for the operation of a UL-approved device in UL-approved systems. Possibly the drive system is not operated in compliance with UL if the corresponding measures are not taken.
	Warnings! Safety or application note for the operation of a UR-approved device in UL-approved systems. Possibly the drive system is not operated in compliance with UL if the corresponding measures are not taken.

General safety instructions



Danger!

Disregarding the following basic safety measures may lead to severe personal injury and damage to material assets!

- ▶ Lenze drive and automation components ...
 - ... must only be used for the intended purpose.
 - ... must never be operated if damaged.
 - ... must never be subjected to technical modifications.
 - ... must never be operated unless completely assembled.
 - ... must never be operated without the covers/guards.
 - ... can - depending on their degree of protection - have live, movable or rotating parts during or after operation. Surfaces can be hot.
- ▶ All specifications of the corresponding enclosed documentation must be observed.

This is vital for a safe and trouble-free operation and for achieving the specified product features.

The procedural notes and circuit details provided in this document are proposals which the user must check for suitability for his application. The manufacturer does not accept any liability for the suitability of the specified procedures and circuit proposals.
- ▶ Only qualified skilled personnel are permitted to work with or on Lenze drive and automation components.

According to IEC 60364 or CENELEC HD 384, these are persons ...

 - ... who are familiar with the installation, assembly, commissioning and operation of the product,
 - ... possess the appropriate qualifications for their work,
 - ... and are acquainted with and can apply all the accident prevent regulations, directives and laws applicable at the place of use.

Residual hazards



Danger!

Dangerous electrical voltage

The terminals of the brake resistor may carry dangerous voltages during operation of the basic device and **up to three minutes after mains disconnection.**

Possible consequences:

- ▶ Death or severe injuries when touching the terminals.

Protective measures:

- ▶ Before working on the brake resistor disconnect the basic device from the mains.
- ▶ Check all power terminals for safe isolation from supply.
- ▶ Select the mounting location so that the operating conditions mentioned in the technical data are always ensured.



Danger!

Hot surface during operation

During operation, the brake resistor becomes very hot. (For temperatures, see Technical data.)

Possible consequences:

- ▶ Severe burns when touching the brake resistor.
- ▶ Fire or smouldering fire if flammable materials or substances are placed near the brake resistor or may get to it.

Protective measures:

- ▶ Before working on the brake resistor, check its surface temperature.
- ▶ Select the mounting location so that the operating conditions mentioned in the technical data are always ensured.
- ▶ Protect the mounting location by suitable fire prevention and protection against contact.

2 Safety instructions

Residual hazards



Stop!

Possible overheating of the brake resistor during operation

Inadequate heat dissipation during operation can cause the brake resistor to overheat.

Possible consequences:

- ▶ The brake resistor is destroyed.
- ▶ The drive is not braked but coasts to a standstill.

Protective measures:

- ▶ Always connect the thermal contact of the brake resistor.
- ▶ Integrate the thermal contact into the overall equipment monitoring apparatus in such a way that the supply of power to the standard device is switched off if the brake resistor overheats (e.g. switch-off by means of mains contactor control).

Overview

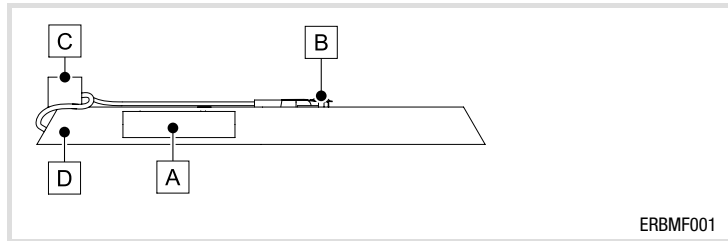

Scope of supply

Pos.	Description
	Brake resistor
	Mounting Instructions

Brake resistor elements

Pos.	Description
A	Nameplate
B	Thermal contact
C	Terminals RB1, RB2, T1, T2
D	PE connection

Identification

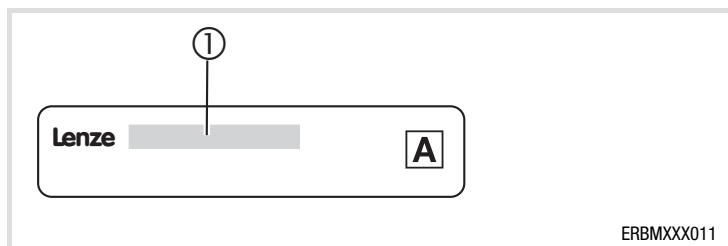

	①		
Type code	ERBx	xxxx	xxxx
Product series			
Resistance R_B [Ω]			
e.g. 470R = 470 Ω			
075D = 7.5 Ω			
Permanent power P_d [W]			
e.g. 120W = 120 W			
01k2 = 1.2 kW			

3 Product description

Application as directed

Application as directed

Brake resistors

- ▶ must only be actuated under the operating conditions specified in these operating instructions.
- ▶ are components
 - for mounting in a machine.
 - for assembly with other components to a machine.Commissioning of the brake resistor is prohibited until it has been determined that the machine into which the brake resistor is to be mounted complies with the regulations of the EC Machinery Directive.
- ▶ are electrical equipment for mounting in control cabinets or similar closed electrical operating areas.
- ▶ comply with the protective requirements of the "Low voltage" EC Directive.
- ▶ are not machines as defined by the Machines EC Directive.
- ▶ are not household appliances, but are only designed as components for subsequent commercial use.

Drive systems with brake resistors

- ▶ The responsibility for compliance with the EC Directives in the machine application is that of the re-user.

Any other use shall be deemed inappropriate!

Dimensioning conditions

If brake resistors are used, observe the following:

- ▶ Mean value of regenerative power < permanent power P_d of the brake resistor.
- ▶ Regenerative power during braking time < heat quantity Q_B of the brake resistor.
- ▶ Braking time < 10 % of cycle time (braking time + dead time).
- ▶ Always connect the thermal contact and integrate it in a way into the system monitoring that the mains supply will be switched off when the standard device is overheated.

At all times, the following must apply: In the time interval $t_{cyc, RB}$ (brake resistor cycle) the cumulative braking times t_{brk} must always be \leq of the maximum total braking time $t_{brk, max}$.

Calculation

Brake resistor cycle $t_{cyc, RB}$:

$$t_{cyc, RB} = \frac{Q_B}{P_d} \text{ with}$$

Q_B Heat quantity in Ws

P_d Permanent power in W

Max. total braking time $t_{brk, max}$ within the time interval $t_{cyc, RB}$:

$$t_{brk, max} = \frac{Q_B \cdot R_B}{U_{max}^2} \text{ with}$$

Q_B Heat quantity in Ws

R_B Resistance in Ω

U_{max} Max. operating voltage in V

3 Product description

Dimensioning conditions

Examples of the evaluation of the condition

The brake resistor cycle $t_{\text{cyc, RB}} = 150 \text{ s}$ and the max. total braking time $t_{\text{brk, max}} = 10 \text{ s}$ are given. The braking times t_{brk} and the process cycle $t_{\text{cyc, Prc}}$ are exemplary.

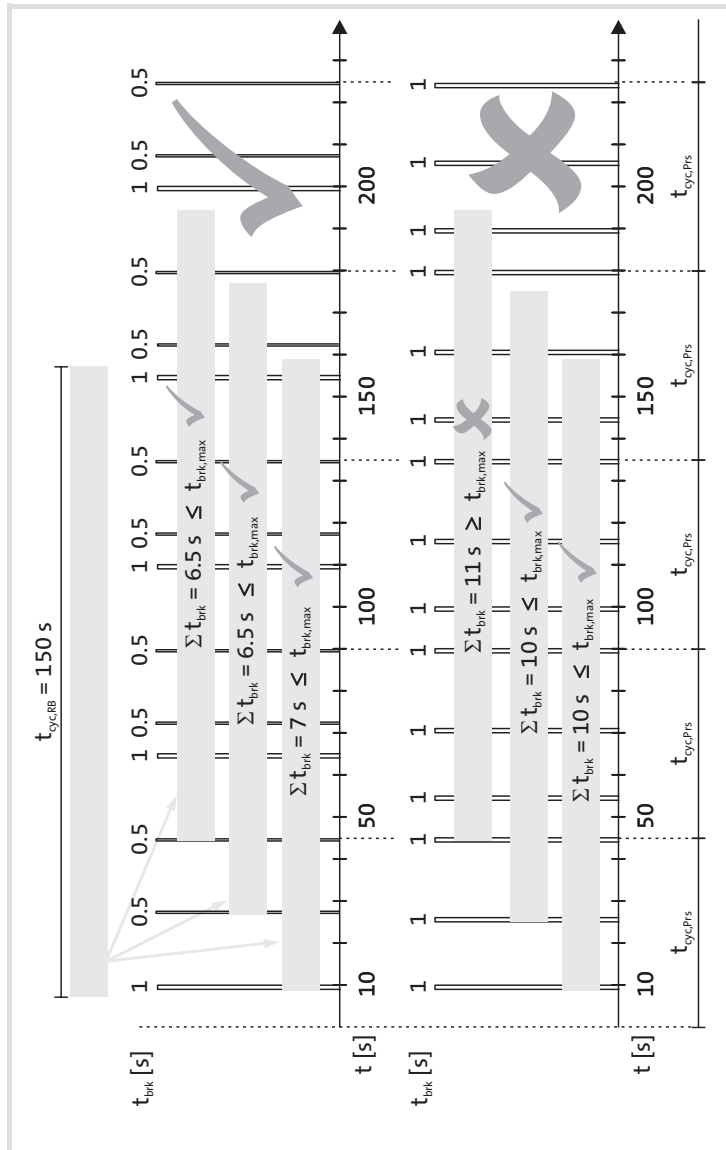

In the above example, the dimensioning condition is observed at all times. In the example below, the dimensioning condition is once not observed, which means that the brake resistor selected is not suitable for the process specified. Use a brake resistor with a greater power (shorter brake resistor cycle $t_{\text{cyc, RB}}$).

General data and operating conditions

Conformity and approval

Conformity

CE	2006/95/EC	Low-Voltage Directive
----	------------	-----------------------

Protection of persons and equipment

Enclosure	EN 60529	IP20	
	NEMA 250	Protection against contact to type 1	
Thermal contact			
Design		NC contact, 130 °C	
Switching capacity		250 V AC / 0.5 A	

Environmental conditions

Climate

Storage	IEC/EN 60721-3-1	1K3 (-25 ... +60 °C)
Transport	IEC/EN 60721-3-2	2K3 (-25 ... +70 °C)
Operation	IEC/EN 60721-3-3	3K3 (-10 ... +55 °C) Current derating from +45 ... +55 °C: 2.5 %/°C
Site altitude		0 ... 4000 m amsl 1000 ... 4000 m amsl: Current derating 5 %/1000 m
Vibration resistance (9.81 m/s ² = 1 g)	EN 50178, IEC 61800-5-1, Germanischer Lloyd, general conditions	Acceleration resistant up to 1 g

Mounting conditions

Mounting location		<ul style="list-style-type: none"> • In the control cabinet • The mounting location must comply with the device features mentioned in the chapter "General data". • Flammable materials or substances may not be placed in the vicinity of the brake resistor. • The heat generated by the brake resistor must be dissipated freely.
Mounting position		Vertically suspended with connecting cables at the bottom.
Free space		
at the top		> 100 mm
at the bottom		> 100 mm
to the sides		> 25 mm

4 Technical data

Rated data

Rated data

Electrical data				
	R_B	P_d	Q_B	U_{max}
	[Ω]	[W]	[kWs]	[V _{DC}]
ERBM470R020W	470	20	3.0	800
ERBM100R035W	100	35	4.5	

R_B	Resistance
P_d	Permanent power
Q_B	Heat quantity
U_{max}	Max. operating voltage

Temperatures			
	T_{nom}	T_{TK}	T_{max}
	[°C]		
On the surface	150	250	500
On the clearance edge *)	90	100	120

T_{nom}	Maximum temperature for rated data
T_{TK}	Temperature at which the thermal contact is activated
T_{max}	Maximum temperature in the case of improper use
*)	Measured for air as the ambient medium (small coefficient of thermal conductivity); if materials which heat up are located at the clearance edge (greater coefficient of thermal conductivity), the temperature continues to rise.

Mechanical data

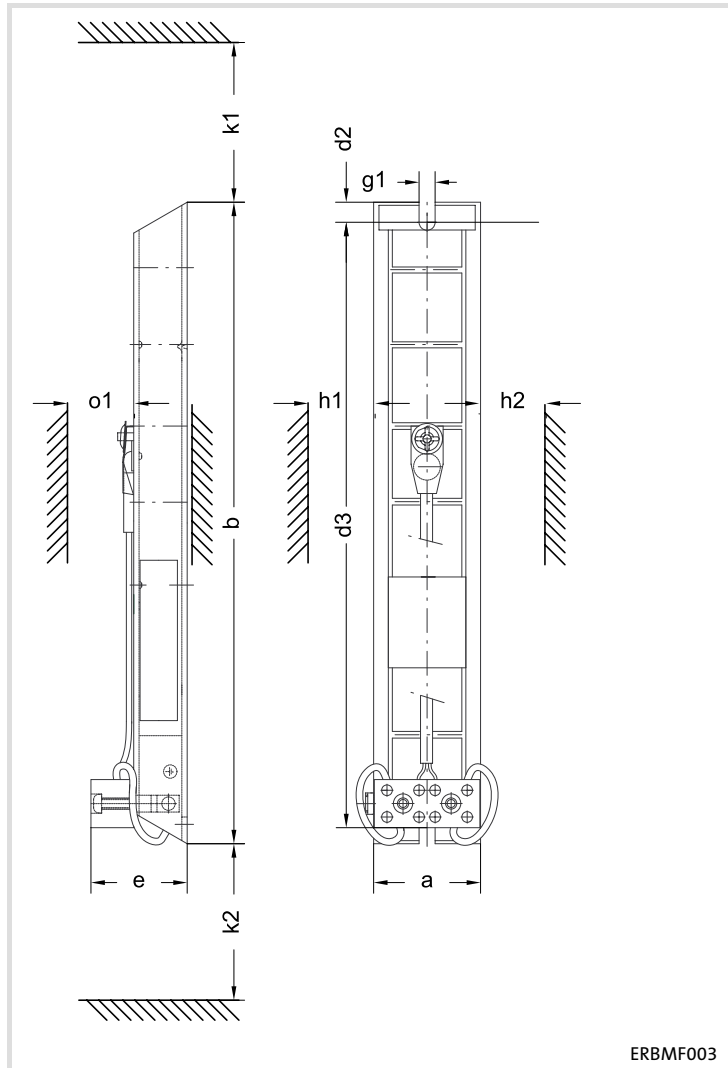

ERBMF003

	a	b	e	d2	d3
	[mm]				
ERBM470R020W	40	160	36	7.5	145
ERBM100R035W		240			225

	g1	h1	h2	k1	k2	o1	[kg]
	[mm]						[kg]
ERBM470R020W	6	25	25	100	100	25	0.25
ERBM100R035W							0.52

Mounting steps

How to mount the brake resistor:

1. Select a suitable mounting location.
 - The mounting location must always ensure the operating conditions mentioned in the technical data; if required, additional measures must be taken.
 - Ensure unimpeded air circulation for heat dissipation.
2. Screw down the brake resistor at the mounting location.
 - The mounting location and the mounting material must ensure the permanent mechanical connection.

Important notes



Stop!

Possible overheating of the brake resistor during operation

Inadequate heat dissipation during operation can cause the brake resistor to overheat.

Possible consequences:

- ▶ The brake resistor is destroyed.
- ▶ The drive is not braked but coasts to a standstill.

Protective measures:

- ▶ Always connect the thermal contact of the brake resistor.
- ▶ Integrate the thermal contact into the overall equipment monitoring apparatus in such a way that the supply of power to the standard device is switched off if the brake resistor overheats (e.g. switch-off by means of mains contactor control).

Connection data

Connection	Connection type	Connection size	Tightening torque
RB1, RB2 (Brake resistor)	Screw terminals	0.33 ... 4 mm ² 22 ... 12 AWG	0.5 Nm 4.4 lb-in
T1, T2 (Thermal contact)			
PE (protective conductor)	Flat connector	6.3 x 0.8	-

6 Electrical installation

Connection plan

Connection plan

Version 1 (short cables)

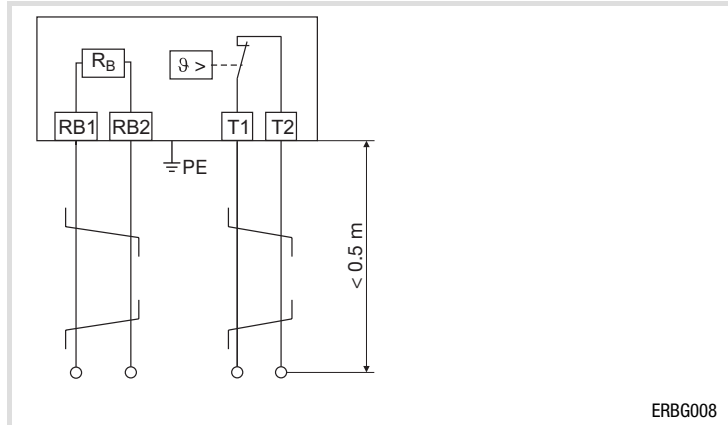

 Twisted cables

Version 2 (long cables)

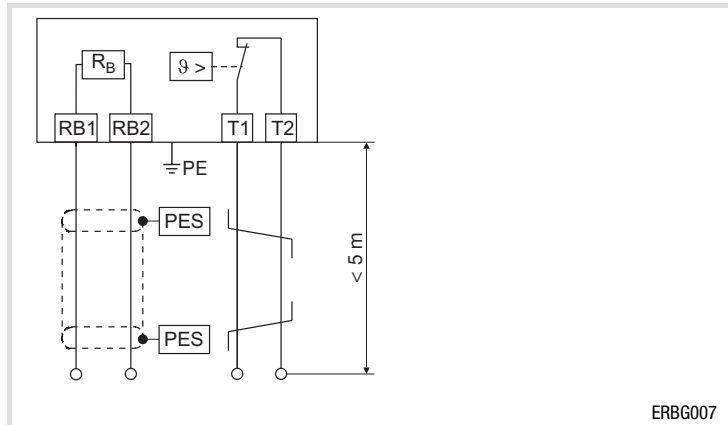

 HF-shield termination by extensive PE connection

 Twisted cables

Mounting steps

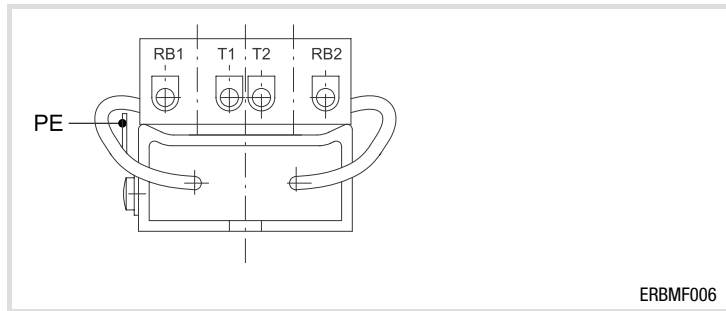

How to connect the brake resistor:

1. Disconnect the basic device from the mains and check all power terminals for safe isolation from supply.
2. Installing the brake resistor cable:
 - Use twisted cables for a cable length up to 0.5 m (connection plan version 1).
 - Use shielded cables for a cable length up to 5 m (connection plan version 2).
 - Connect cores to the terminals RB1, RB2 and PE, tightening torque must be observed. Connect PE according to EN 61800-5-1.
 - Apply cores and shield to the basic device; the documentation of the basic device must be observed.
3. Installing the thermal contact cable:
 - Use the twisted cable.
 - Connect cores to the terminal T1 and T2; tightening torque must be observed.
 - When integrating the thermal contact into the system monitoring ensure that the mains supply will be switched off when the brake resistor is overheated.

Maintenance intervals

The brake resistor is maintenance-free. Nevertheless, a visual inspection must be executed in short and regular intervals considering the ambient conditions.

Ensure that:

- ▶ the environment of the brake resistor still corresponds to the operating conditions included in the technical data.
- ▶ no dust or dirt impedes the heat dissipation of the brake resistor.
- ▶ the mechanical and electrical connections are correct.

Maintenance operations

Cleaning the brake resistor

1. Disconnect the standard device from the mains and wait at least three minutes.
2. Check temperature of the brake resistor and allow it to cool, if required.
3. Check the brake resistor for safe isolation from supply.
4. Clean brake resistor without using cleaning agents.